



EU-Project HEIDI Research Activities on Human-Machine-Interfaces

2026-02-03

R. Leute, F. Maier, M. Paulokat, E.-O. Rosenhahn

HEIDI has received funding from the European Union's Horizon Europe research and innovation programme under Grant Agreement No. 101069538.



A decorative graphic consisting of two intersecting diagonal lines that form an 'X' shape. A vertical line is positioned to the left of the intersection point. The word 'Introduction' is written in a light blue font to the right of the vertical line.

Introduction

HEIDI

Holistic and adaptive Interface Design for human-technology Interactions



- Funded project of the European commission
- Development and evaluation of internal, external and cooperative HMI
- 09/2022 → 08/2025,
- 3 years duration



External
HMI

International Partners:

- BMW, Germany
- Reutlingen University, Germany
- Honda Research Institute, Germany
- Marelli Germany GmbH,
- NiSys, Germany
- VTI, Sweden
- Tree Technology, Spain
- Universidad de Alcalá, Spain
- Virtual Vehicle, Austria



Focus eHMI

Goal w/ Industry Perspective

- Create a „**realistic**“ communication display
 - form follows function
 - adaptable to **entry** level and **high** level cars
 - demonstrate **efficacy** in **near-real-world scenario**
 - clear scenario, high number of interactions
 - **measured data** + questionnaires
 - create proposal for **regulatory framework**
- ➔ Enable a „new“ light function in mid-term-future

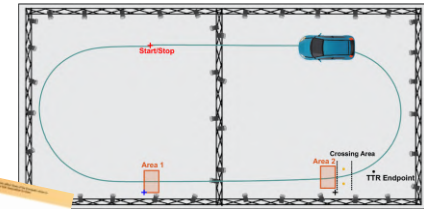
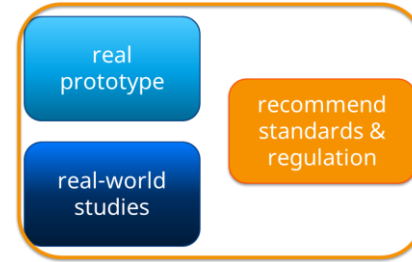

2

Basic Lighting Parameters

Real World Experiment on Signal Matrix

Results out of the Test Runs: Luminance Needs

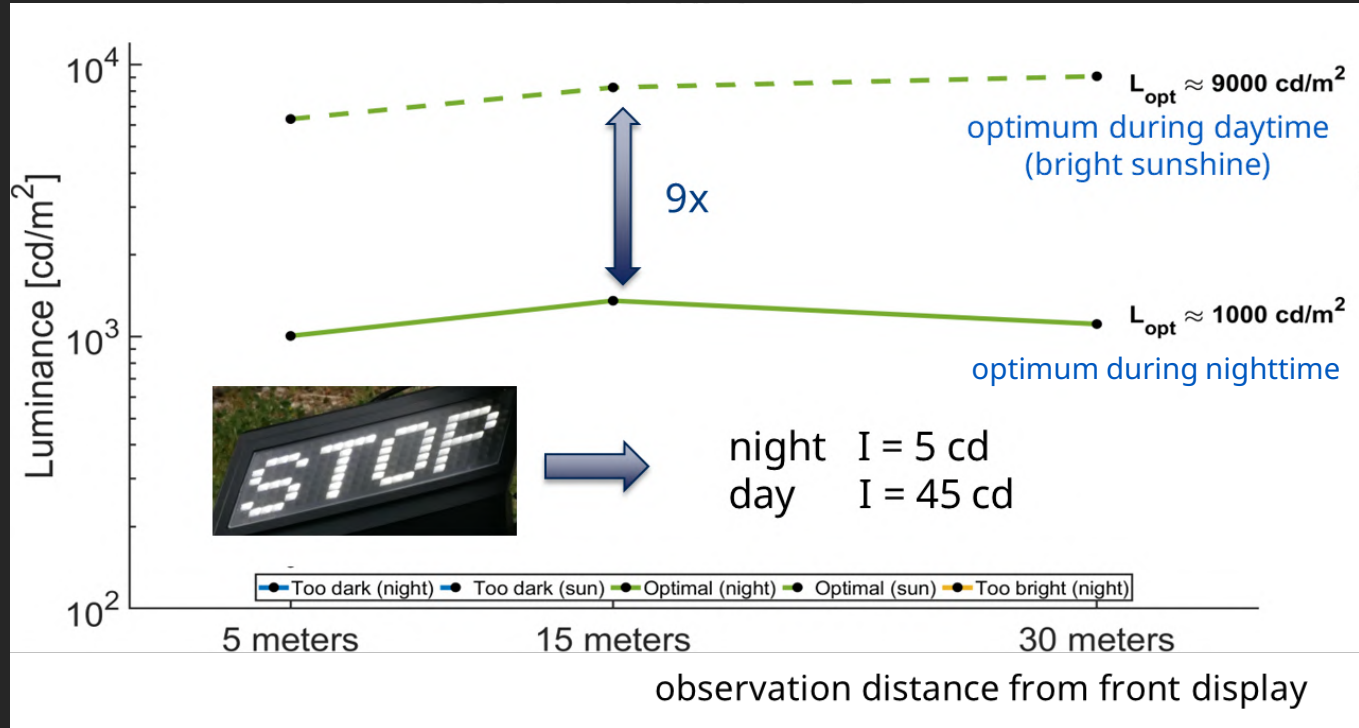

Future Signal Matrix Applications

Results: Font Size evaluation (4 – 6 rating) Readability

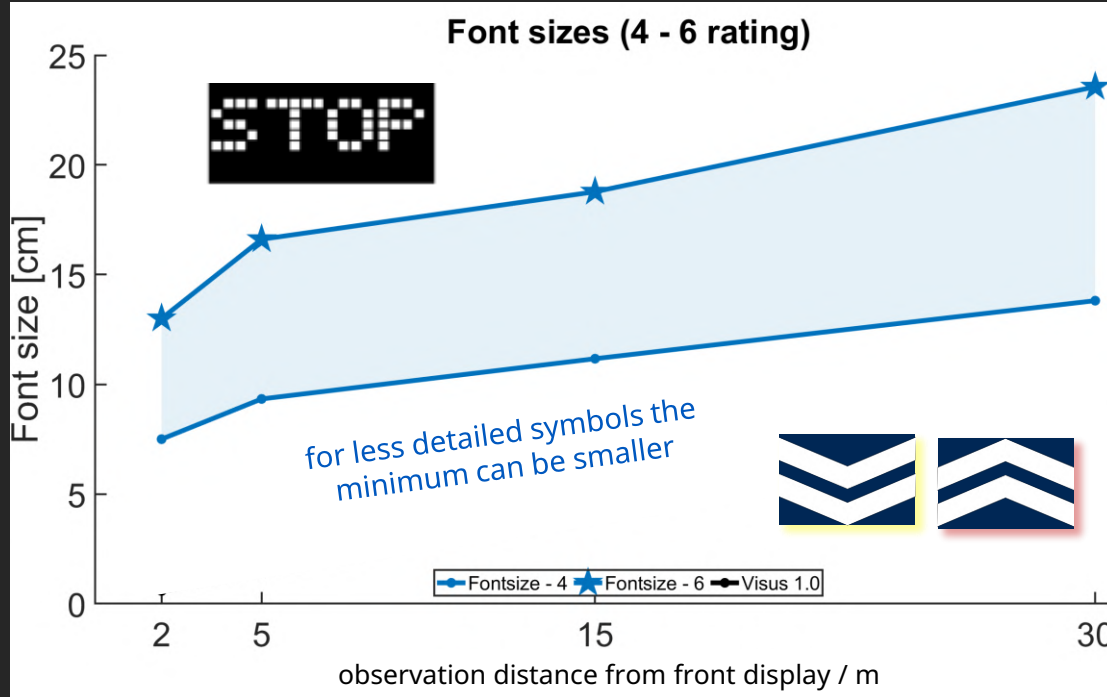

Future Signal Matrix Applications

Guideline for Lighting Parameters for Frontlighting Display Communication:

„Active“ sector size:

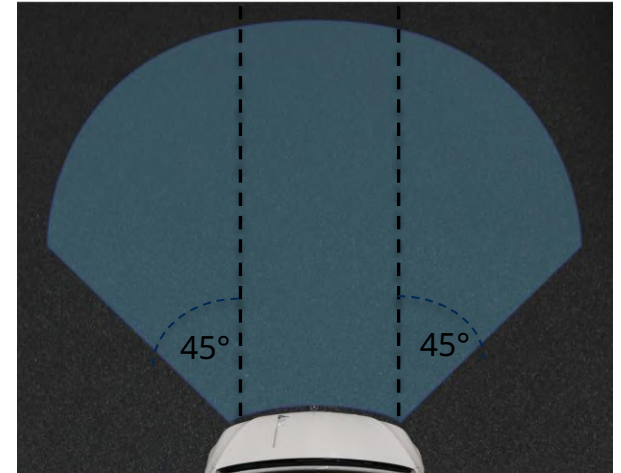
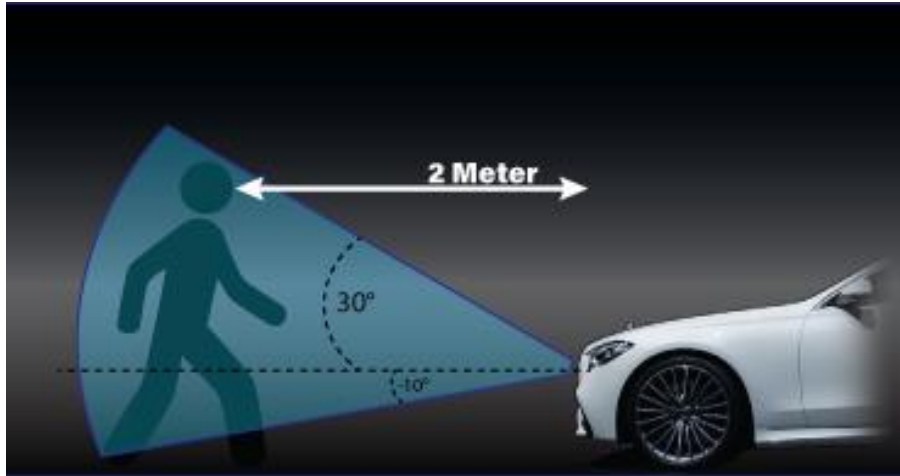

2

Prototype

Heidi optical design

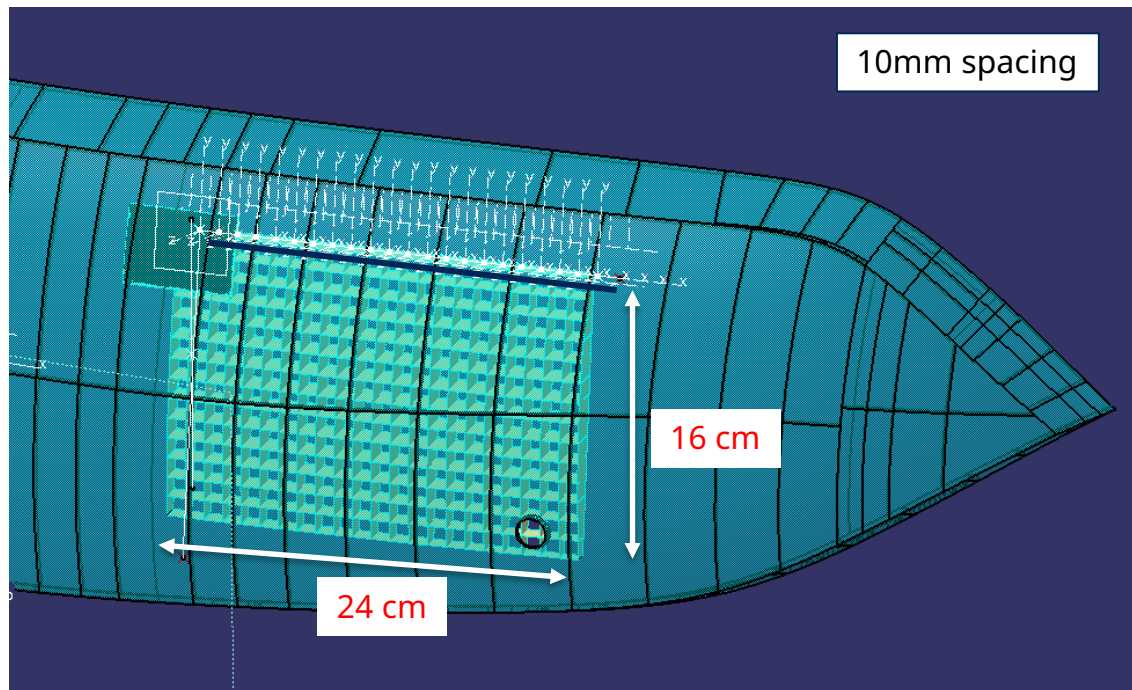
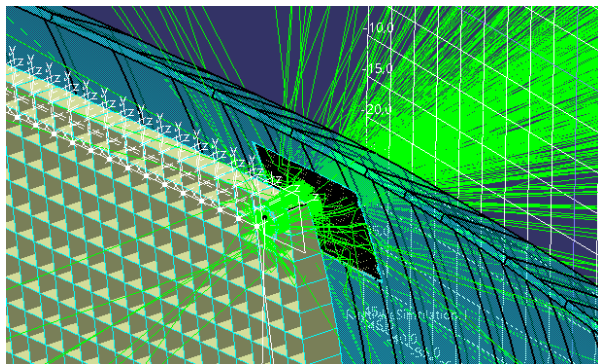
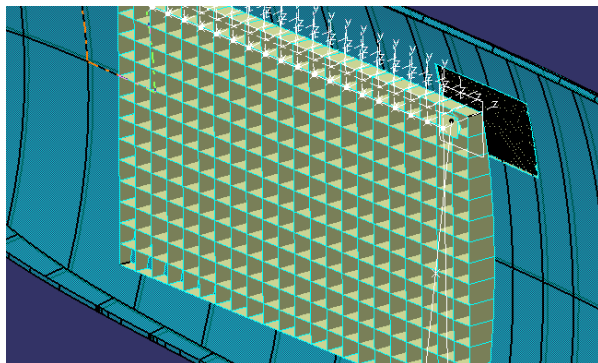

eHMI Prototype Concept



- 24x16 pixels, 10 mm pitch
- 384 Osram iRGB LEDs
- 9000 nits (cd/m²) (adjustable)
- asymmetric viewing angles
- integrated to panel

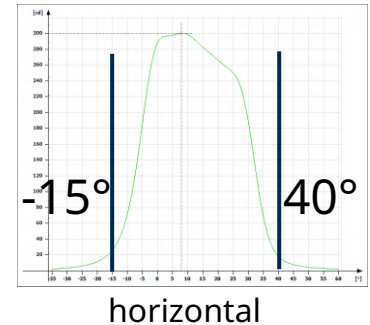
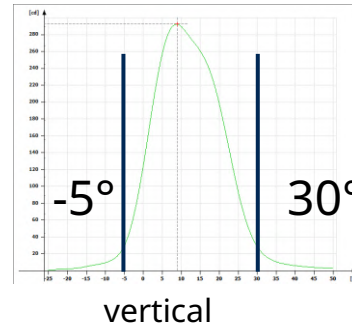
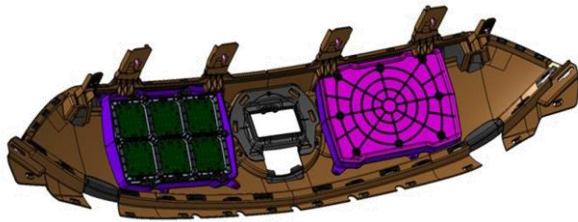
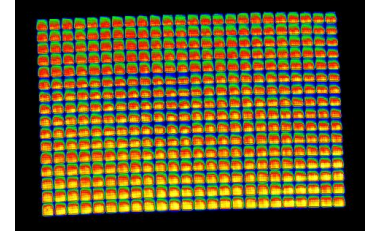
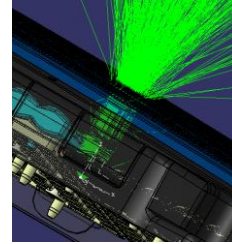
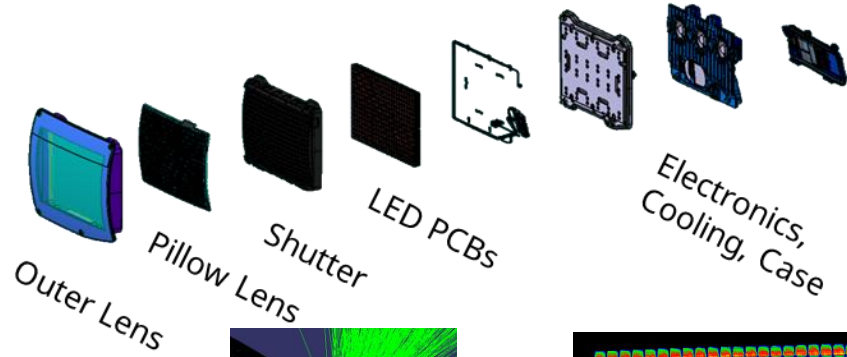

EU Funded Project: HEIDI Displays on Test Vehicle

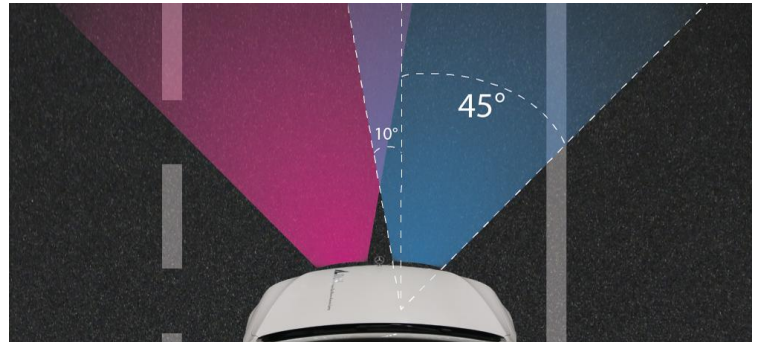



Evaluation Setup

eHMI Display

- 16 x 24 RGB Pixels

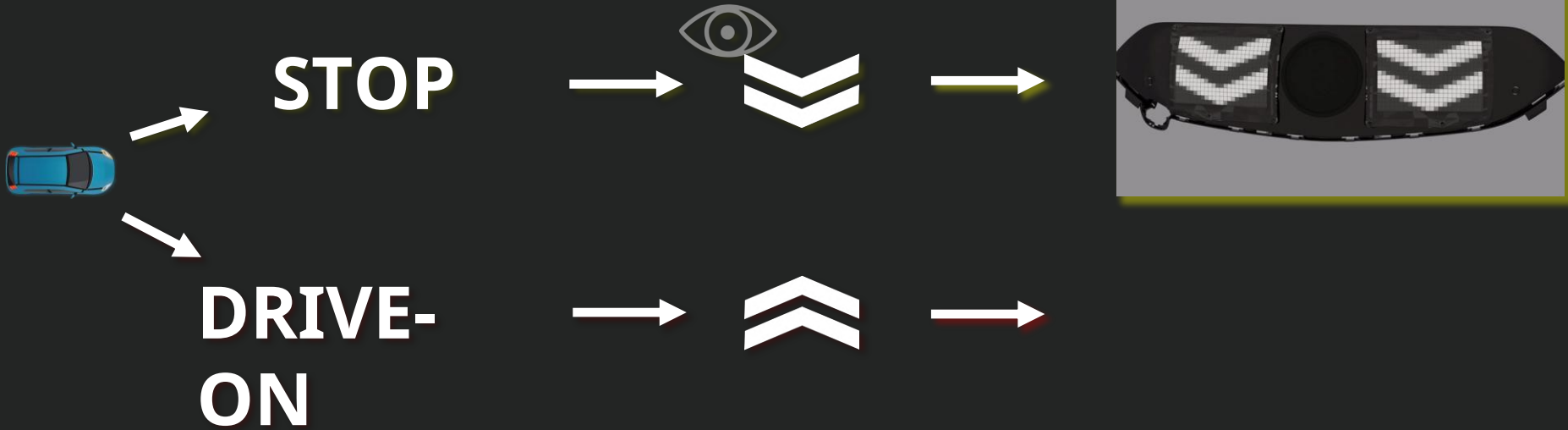

3D Motion Tracking



- 60 m x 30 m „Trackable“ Area
- 38 IR-Motion Tracking Cameras
- Multi-Object Tracking
 - Simultaneous Tracking of Car and Pedestrian



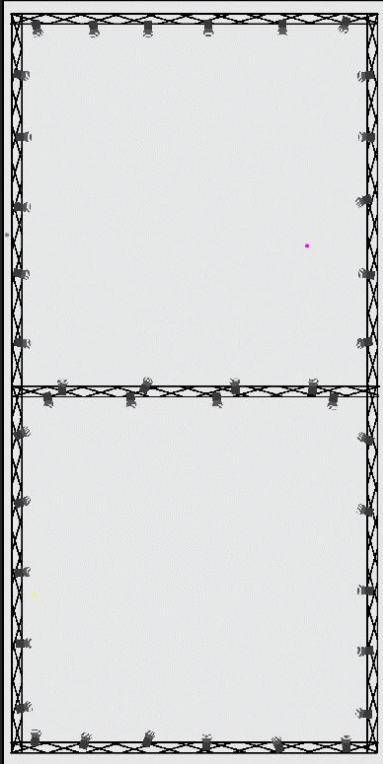

- 27 Participants (7 female)
- 1050+ Interactions
- Several Parameters calculated
 - Velocities, distances, time to collision
 - **Time to resolve (TTR)**

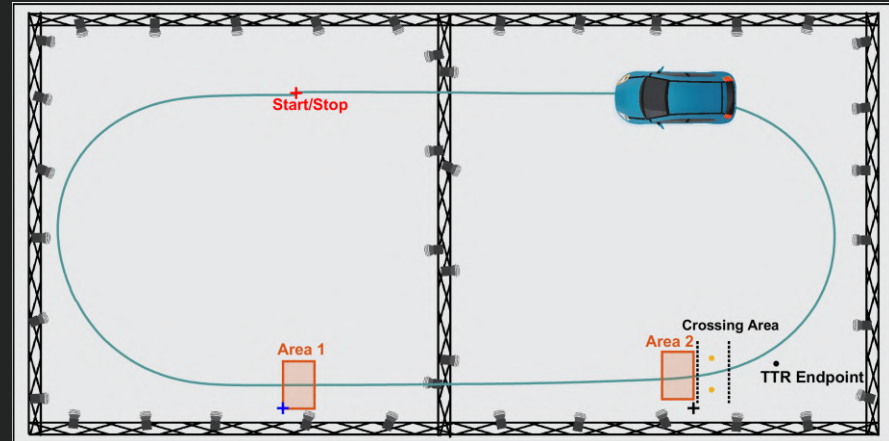

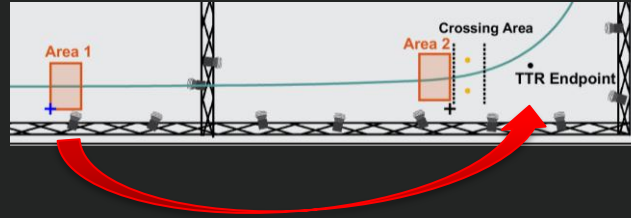

- Time To Resolve (TTR)

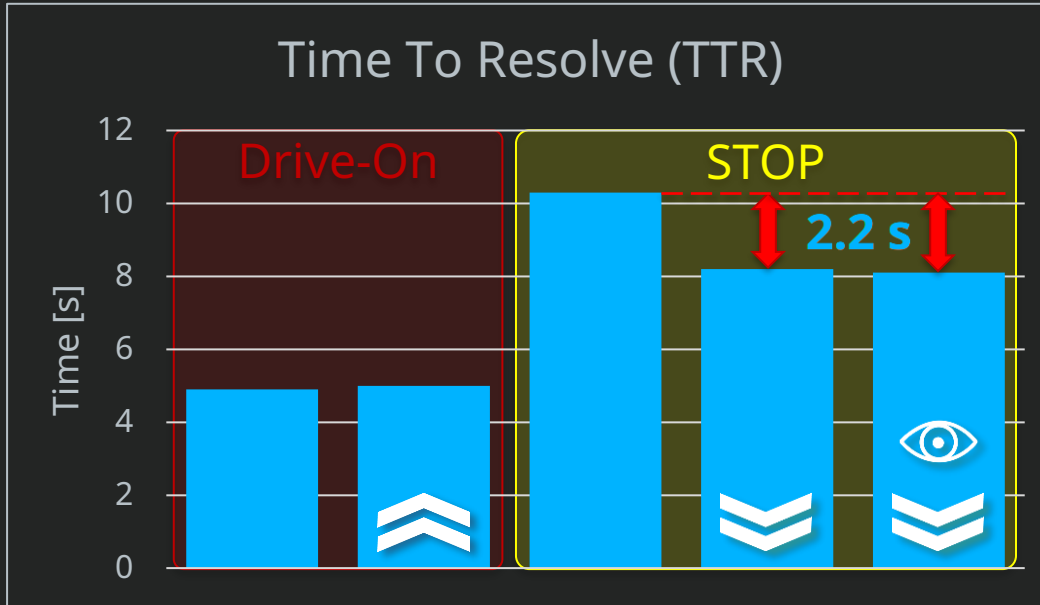

w/o HMI

HMI

Distance: Car - Pedestrian

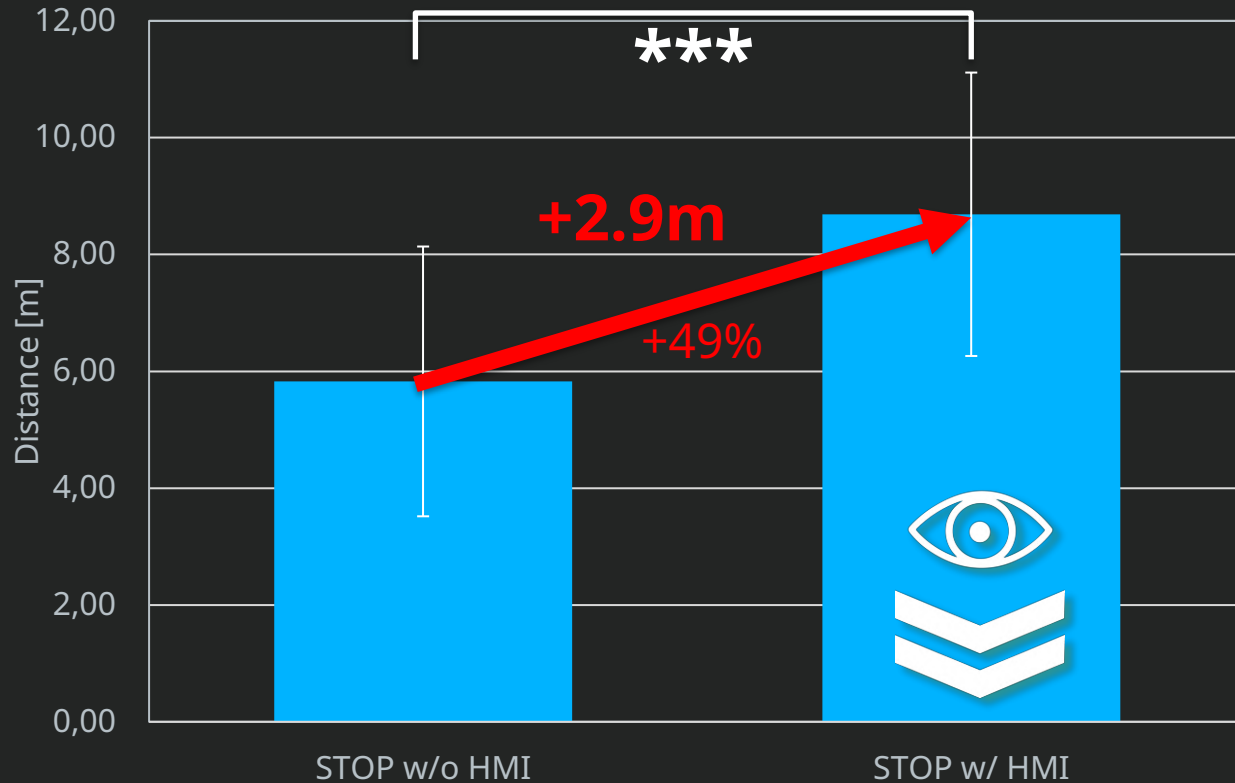

Results Questionnaire

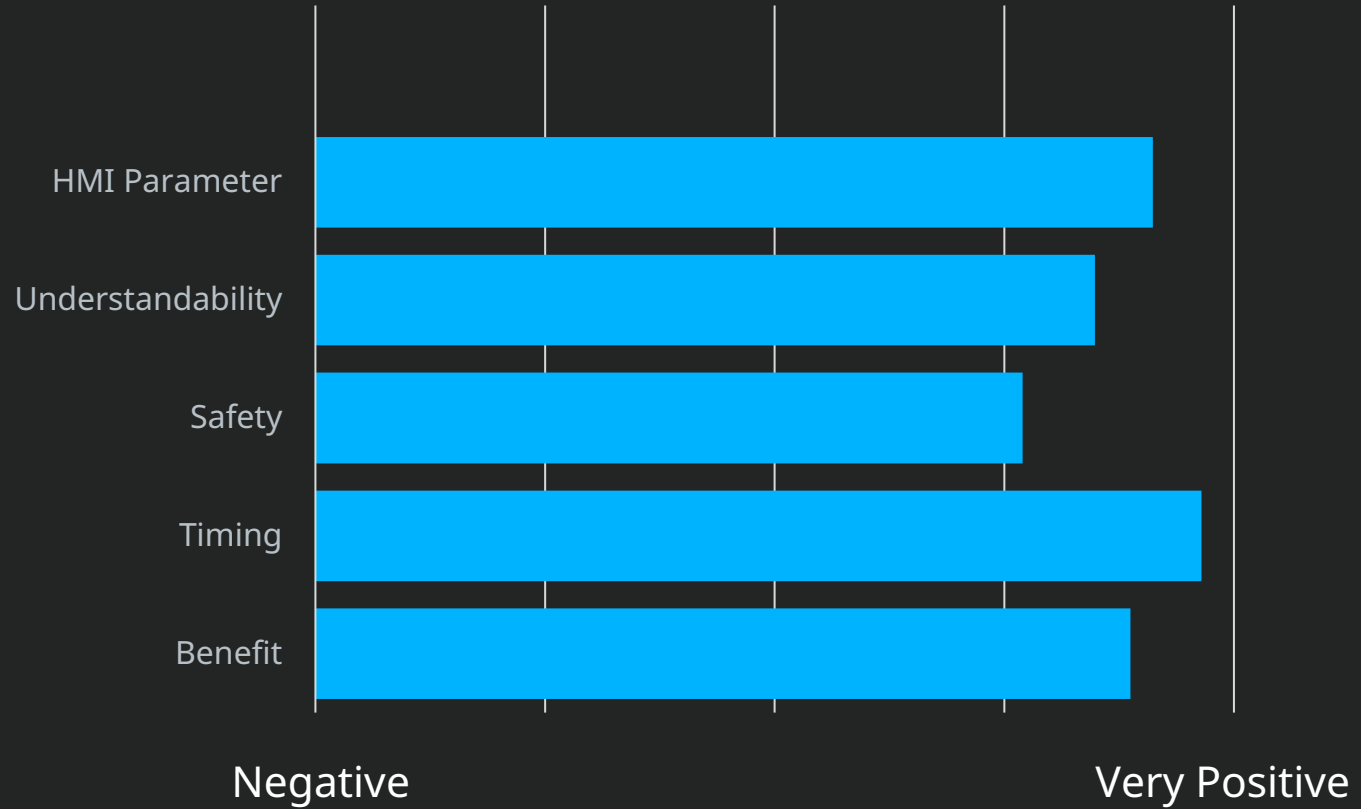

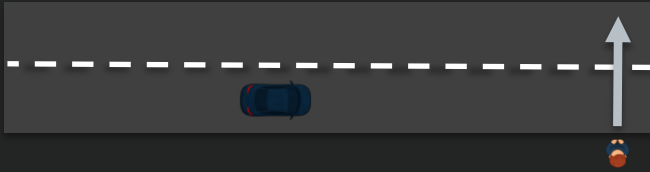

Traffic flow: speed

w/o external Display

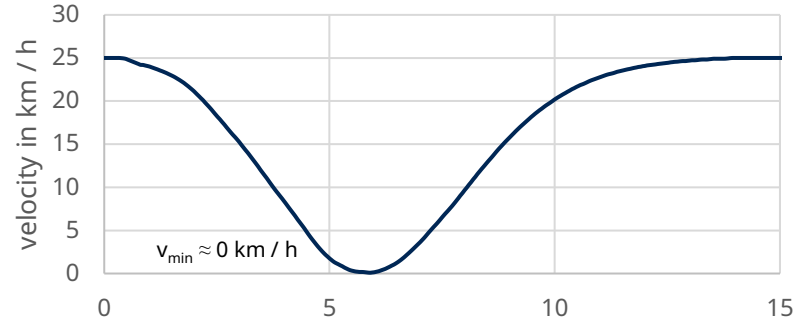

w/ external Display

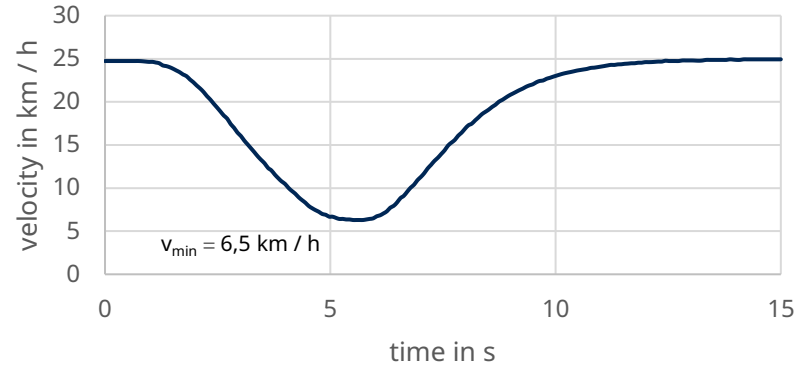

Traffic Flow Simulation

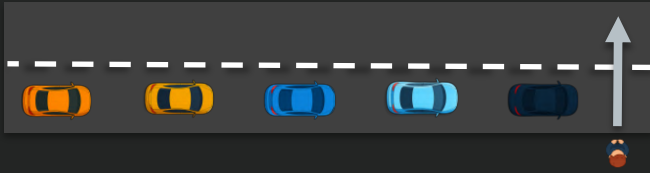

Simulation:

- 5 vehicles
- Distance between cars 18 m
- Velocity at start: 25 km / h

Traffic flow: speed

w/o external Display

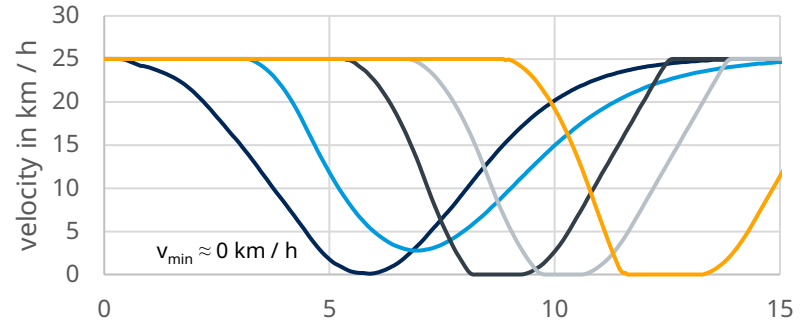

w/ external Display

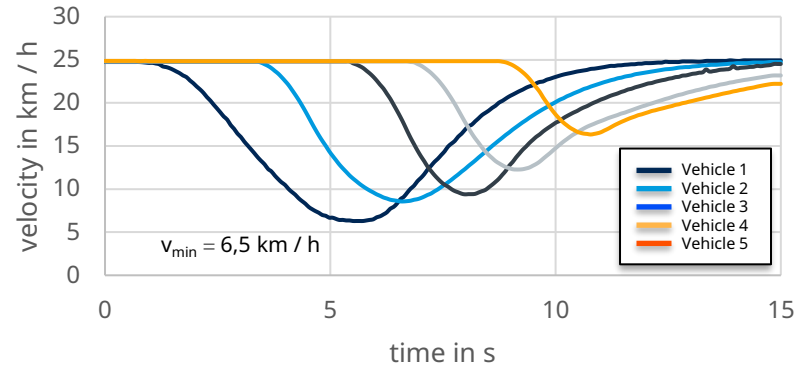

Traffic Flow Simulation

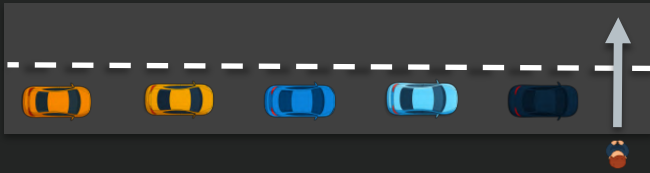

Simulation:

- 5 vehicles
- Distance between cars 18 m
- Velocity at start: 25 km / h

Traffic flow: distance V2V

w/o external Display

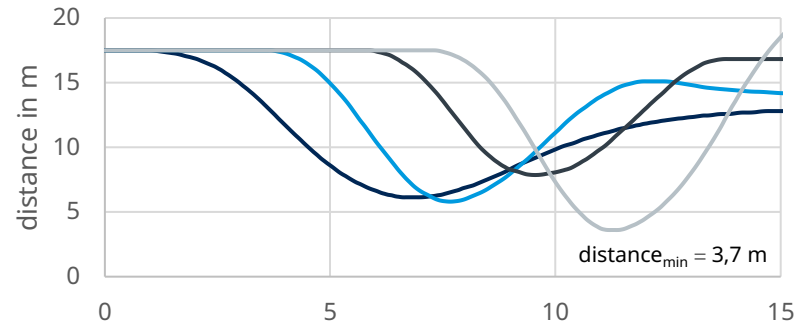

w/ external Display

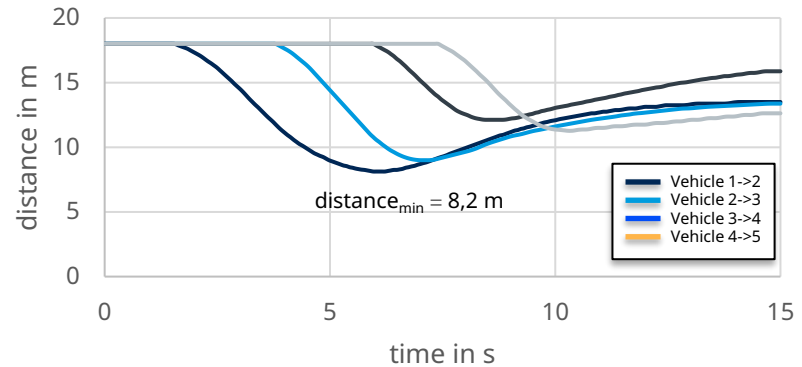



Recommendations for Legal Regulation

Proposal for ECE-Regulation



Views and opinions expressed are those of the author(s) only and do not necessarily reflect those of the European Union or CINEA. Neither the European Union nor the granting authority can be held responsible for them.



Finalised recommendations for legislation proposal and standardisation

Deliverable Number D7.3
Deliverable Type R – Document, Report
Dissemination Level PU (Public)
Author(s) Robert Leute (MAR)
Document Version & Status V2.0 | Final

Finalised recommendations for legislation proposal and standardisation



Table of Contents

1. Executive Summary	5
2. Objectives	6
3. Motivation.....	7
4. Recommendation for eHMI regulation	8
4.1 Placement of eHMI	8
4.2 Optical requirements of eHMI	9
4.2.1 Visibility - Readability	10
4.2.2 Brightness	11
4.2.2.1 Brightness measurements	11
4.2.3 Colour	12
Table 4-4: CIE White boundaries for Illuminance.....	12
Table 4-5: CIE White intersection points.....	12
4.3 Messages to be communicated	13
4.4 Patterns to be displayed	13
4.4.1 Requirements on pattern display	14
5. Recommendation for Vehicle / System requirements	16
5.1 Limitations on use of eHMI	16
6. Conclusion	17
7. Abbreviations	18
8. References.....	20

Proposal for Regulation

Key aspects – position & size

- Placement below windshield & inside POS
- Either single eHMI or one per side of vehicle
- center placement optional
- No requirement on size of eHMI
→ size of pattern/symbol
min: 100 cm², max 800 cm²

HEIDI display ~400 cm²

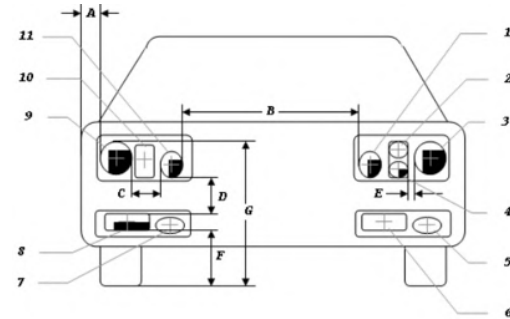

Proposal for Regulation

Key aspects – brightness & colour

- **adaptive** brightness
 - 700 – 1500 cd/m² → night
 - >3000 cd/m² → cloudy day
 - >9000 cd/m² → bright day
 - adapt to environment (rain, fog, etc.)
- **mandatory** colour for messaging **white**
 - cyan optional
 - amber optional in connection to emergency brake etc.



Proposal for Regulation

Key aspects – messages & patterns

- **Three Messages**
 - Vulnerable Road User (VRU) **detected**
 - Vehicle will **decelerate / stop**
 - Vehicle stays **at speed / accelerates**
- **Pattern requirements**
 - recognizable at distance
 - dynamic (either moving or segmented)

Flashing permitted

No conflicting patterns at same time



Proposal for Regulation

Key aspects – vehicle requirements & limitations

- **Vehicle requirements**

- ADAS level 3 or higher
- reliably detect VRUs at distances of 30 m
- recognize VRU intention
- calculate time to collision and similar metrics

- **Limitations**

- only active at speed <55 km/h
- Fail State = OFF



LIDAR
CAMERA 
EYE-TRACKING



RADAR 
LIDAR
CAMERA (VIS, IR)
V2X COMMUNICATION
(LIFI)



Thanks!